

POPRAWKI			
POPRAWKA	OPIS	DATA	ZATWIERDZONE
A	USUNIĘCIE TASIEMKI	14-10-2021	WALEŃSKI

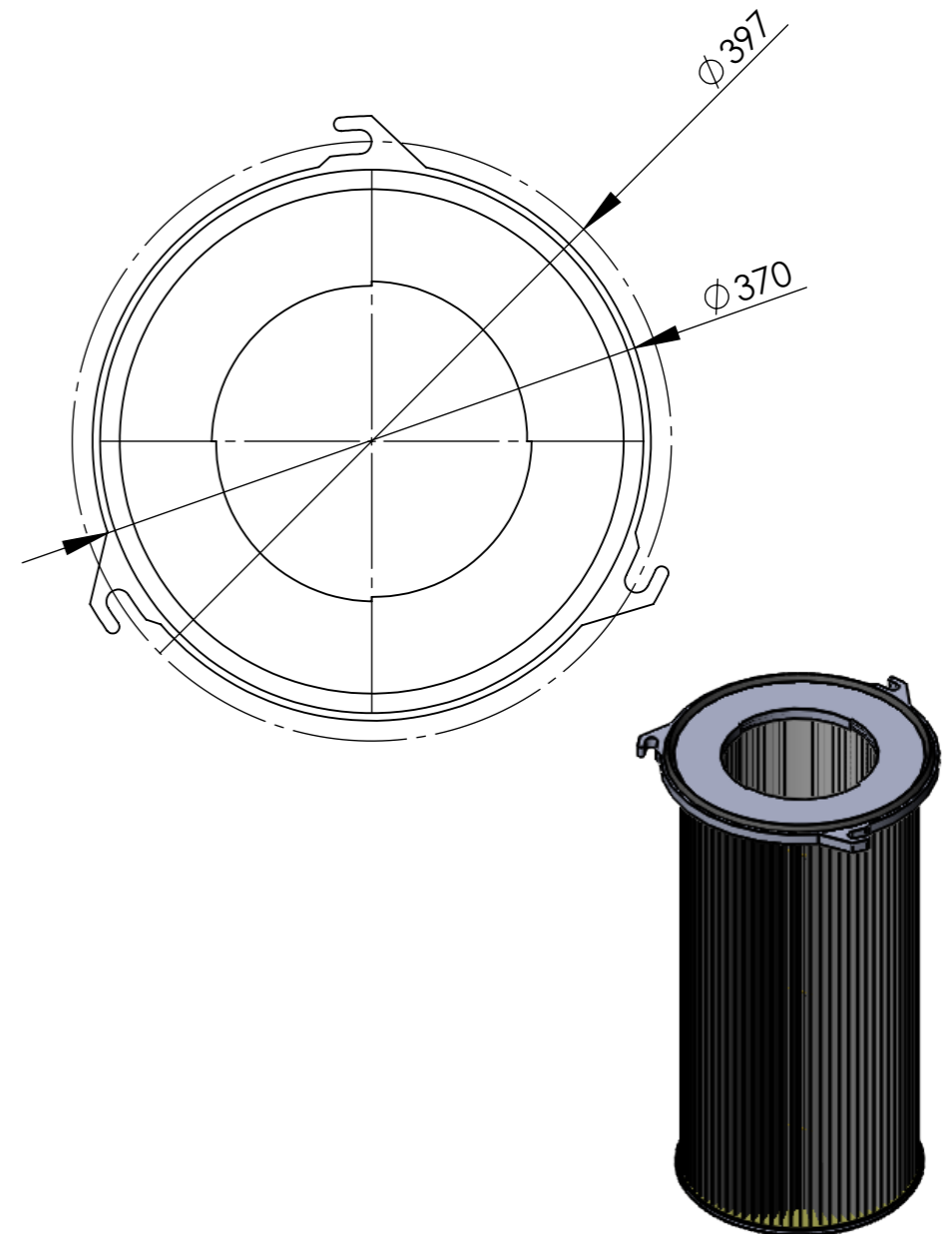
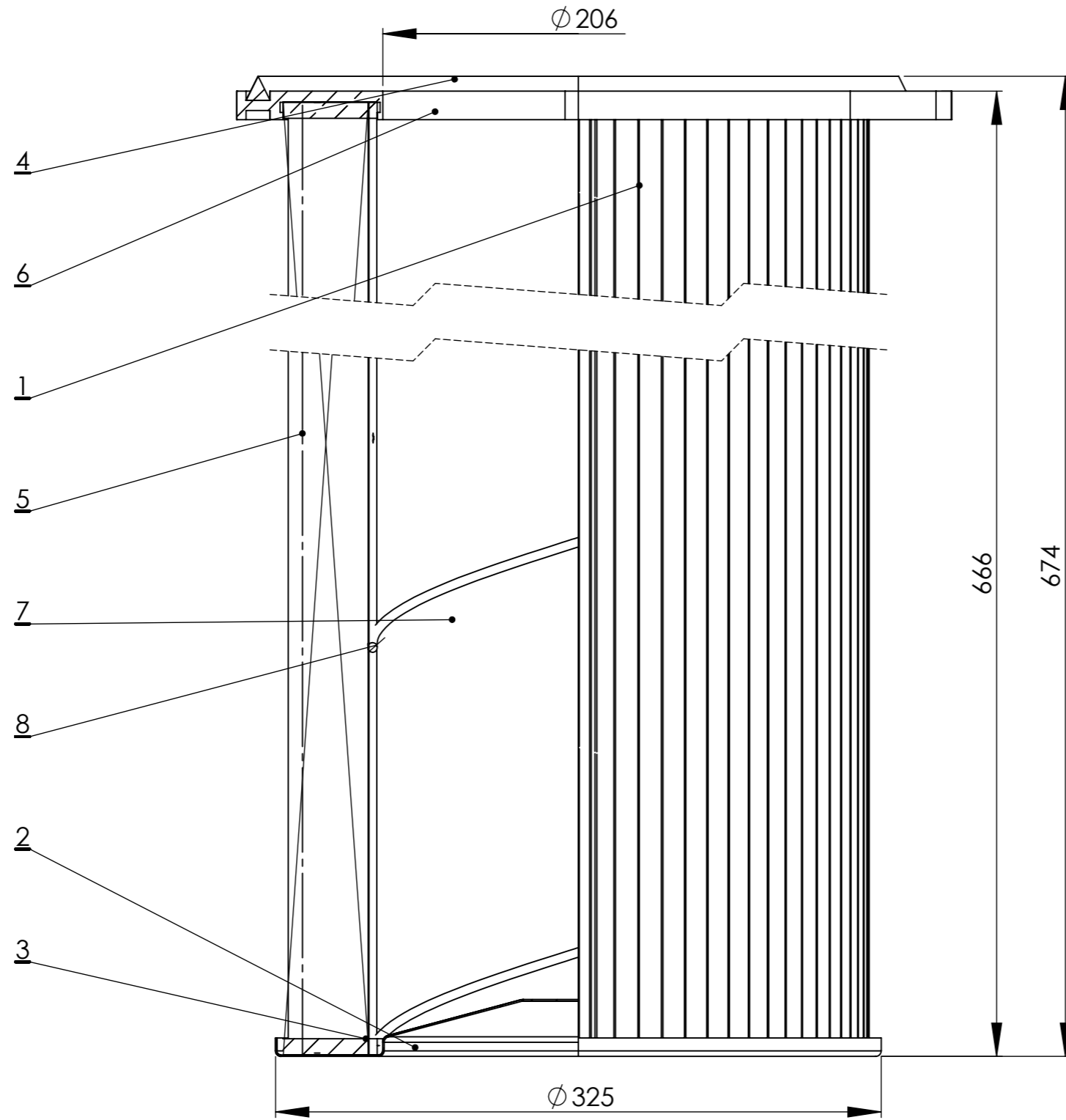

PLEATED ELEMENT PROPERTIES		
FILTER MEDIA		M-658.44.182.P-115
FILTRATION AREA	m2	10
PAPER WIDTH	mm	658
PLEATS HIGHT	mm	44
PLEATS NUMBER	pcs	182
CAPACITY	g	
EFFICIENCY	%	

NO	NAME	PSC	MATERIAL
10			
9			
8	Stróżka wewnętrzna/Trickle of glue	1	T-020; 120 gram
7	Rdzeń / Reinforcement	1	R-228.657
6	Flansa ALU4-3 (320)	1	Aluminium
5	Klej / Glue	1	T-010; 6,6 gram
4	Uszczelka / Gasket	1	SP-187
3	Klej / Glue	2	T-001; 765 gram
2	Denko Dolne / Bottom cap C-0102	1	Blacha ocynkowana
1	Mieszek / Pleated element	1	P-115

SCALE	SIZE	Nazwisko	Data
1:3		Konstruował	Waleński M
		Sprawdził	Marcinkowski P
		Zatwierdził	Piotrowski P

NAME		IFA-9777T.10	
DRAWING NO			

GENERAL TOLERANCES FOR DRAWING DIMENSIONS				
Dimension	5	5-30	30-100	120-400
Tolerance	±0,20	±0,30	±0,50	±1,30

